

***INO-CUT***

***Drehwerkzeuge***

*INO-CUT turning tools*

*INO-CUT porte-outils*



[www.dieterle-tools.com](http://www.dieterle-tools.com)



# Übersicht *Summary*

## INO-CUT Werkzeugsystem zur Bohrungsbearbeitung ab Bohrungs-Ø 7,8 mm

INO-CUT tool-system for boring and profiling for bore Ø from 7,8 mm



Hartmetall – Klemmhalter Typ 608 / 611 / 614 / 616 ..... 5  
*Toolholder – hard metal type 608 / 611 / 614 / 616*



Stahl – Klemmhalter Typ 608 / 611 / 614 / 616 ..... 6  
*Toolholder – steel type 608 / 611 / 614 / 616*

### Schneidplatten INO-CUT ..... 7–22

*Inserts INO-CUT*

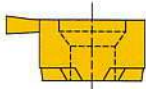
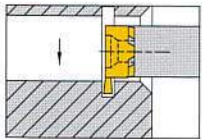

Stechdrehen (Innen) ab Ø 8,0 mm / Ø11,0 mm ..... 8  
*Grooving (internal) for bore Ø from 8,0 / Ø11,0 mm*

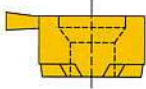
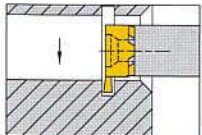

Stechdrehen (Innen) ab Ø 14,0 / Ø 16,0 mm ..... 9  
*Grooving (internal) for bore Ø from 14,0 / Ø 16,0 mm*

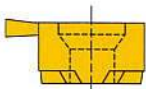
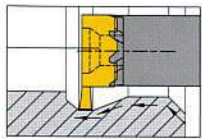

NC-Feindrehen (Innen) ab Ø 8,0 / Ø 11,0 / Ø 14,0 / Ø 16,0 mm ... 10  
*NC-profiling (internal) for bore Ø from 8,0 / Ø 11,0 / Ø 14,0 / Ø 16,0 mm*

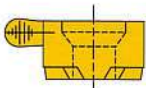
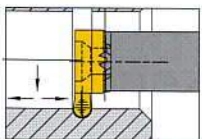

Stechdrehen (Innen) Vollradius ..... 11  
ab Ø 8,0 / Ø 11,0 / Ø 14,0 / Ø 16,0 mm  
*Grooving (internal) for bore Ø from 8,0 / Ø 11,0 / Ø 14,0 / Ø 16,0 mm  
full nose radius*

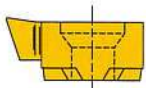
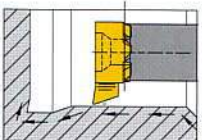

Ausdrehen & Kopieren (Innen) ..... 12  
ab Ø 7,8 / Ø 11,0 / Ø 14,0 / Ø 16,0 mm  
*Boring and copying (internal) for bore Ø from 7,8 / Ø 11,0 / Ø 14,0 / Ø 16,0 mm*

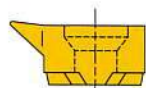
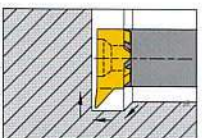









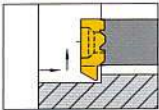

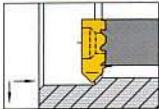
Ausdrehen/Kopieren & Innenfreistriche (DIN 509) ..... 13  
ab Ø 7,8 / Ø 11,0 / Ø 13,7 mm  
*Boring/copying and profiling undercuts (DIN 509)  
for bore Ø from 7,8 / Ø 11,0 / Ø 13,7 mm*

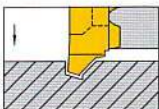
# Übersicht *Summary*

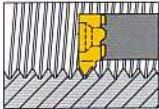
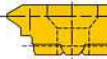
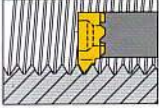
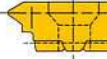
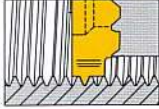
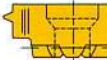
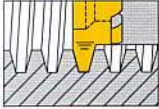
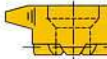
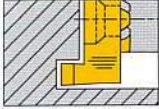
## INO-CUT Werkzeugsystem zur Bohrungsbearbeitung ab Bohrungs-Ø 7,8 mm

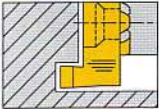
*INO-CUT tool-system for boring and profiling for bore Ø from 7,8 mm*

		Rückwärtsdrehen ( Innen ) ..... 14 ab Ø 7,8 / Ø 11,0 / Ø 13,8 mm <i>Boring by backward motion ( internal ) for bore Ø from 7,8 / Ø 11,0 / Ø 13,8 mm</i>
		Fasen & Ausdrehen ( Innen ) ..... 15 ab Ø 8,0 / Ø 11,0 / Ø 14,0 mm <i>Chamfering and boring for bore Ø from 8,0 / Ø 11,0 / Ø 14,0 mm</i>
		Vorstechen & Fasen ( Innen ) ..... 16 ab Ø 8,0 / Ø 11,0 / Ø 14,0 / Ø 16,0 mm <i>Pregrooving and chamfering for bore Ø from 8,0 / Ø 11,0 / Ø 14,0 / Ø 16,0 mm</i>
		Metrisches Gewinde ( Innen ) ISO Teilprofil ..... 17 ab Ø 8,0 / Ø 11,0 / Ø 14,0 / Ø 16,0 mm <i>Metric thread ISO partial profile for bore Ø from 8,0 / Ø 11,0 / Ø 14,0 / Ø 16,0 mm</i>
		Metrisches Gewinde (Innen ) ISO Vollprofil ..... 18 ab Ø 11,0 / Ø 14,0 / Ø 16,0 mm <i>Metric thread ISO full profile for bore Ø from 11,0 / Ø 14,0 / Ø 16,0 mm</i>
		Whitworth Gewinde ( Innen ) Vollprofil ..... 19 ab Ø 11,0 / Ø 16,0 mm <i>Whitworth full profile for bore Ø from 11,0 / Ø 16,0 mm</i>
		Trapez – Gewinde ( Innen ) ..... 20 ab Ø 11,0 / Ø 16,0 mm <i>Trapezoidal thread profile for bore Ø from 11,0 / Ø 16,0 mm</i>
		Axialstechen ab Ø 12,0 mm ..... 21 <i>Face grooving for bore Ø from 12,0 mm</i>
		Axialstechen ab Ø 14,0 mm ..... 22 <i>Face grooving for bore Ø from 14,0 mm</i>
		Technologiedaten INO – CUT ..... 23 <i>cutting data for INO - CUT</i>

**INO-CUT**

## **HM-Schneidwerkzeuge**

*Carbide Grooving Tools*



**Stechdrehen (Innen)**  
**ab Ø 7,8 mm**

*Grooving (internal)*  
*for bore Ø from 7,8 mm*

# INO-CUT Werkzeugsystem zur Bohrungsbearbeitung

Tools for boring and profiling

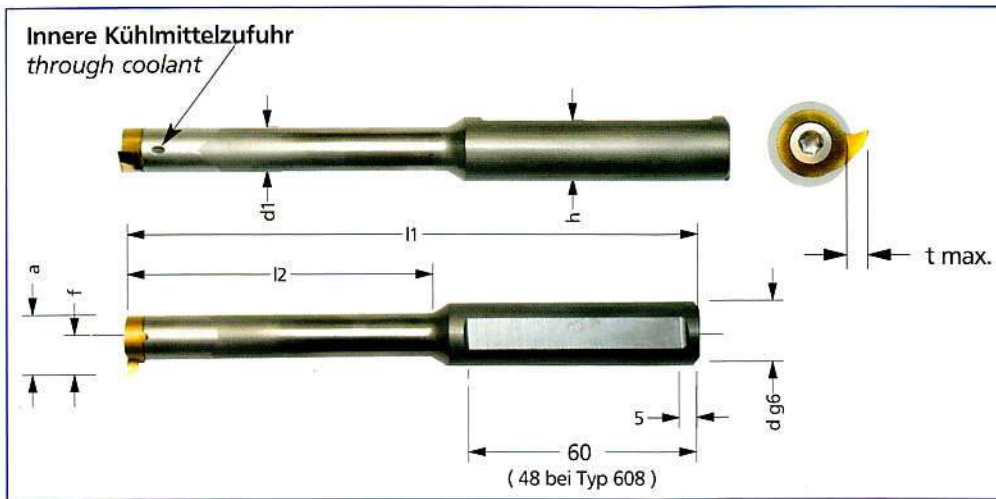

## Hartmetall-Klemmhalter

Toolholder (hard metal)

zum Stechdrehen,  
Ausdrehen und  
Gewindeschneiden  
(innen) ab Ø 7,8 mm  
Grooving boring and  
threading (internal)  
bore Ø from 7,8 mm

Bestellnummer <i>part number</i>	Ødg6	l2	l1	d1	f	a	h	für Schneidplatte <i>use with insert</i>	t max.	D min.	Spannschraube <i>screw</i>
608.0012.1 HM	12	21	80	6	4,8	7,8	11	IC-S08	1,0	8	M2.6-MC
608.0012.2 HM	12	30	90	6	4,8	7,8	11	IC-S08	1,0	8	M2.6-MC
608.0012.3 HM	12	42	100	6	4,8	7,8	11	IC-S08	1,0	8	M2.6-MC
608.0012.4 HM	12	50	115	6	4,8	7,8	11	IC-S08	1,0	8	M2.6-MC
611.0012.1 HM	12	29	95	8	6,7	10,7	11	IC-S11	2,3	11	M3.5-MC
611.0012.2 HM	12	42	110	8	6,7	10,7	11	IC-S11	2,3	11	M3.5-MC
611.0012.3 HM	12	56	120	8	6,7	10,7	11	IC-S11	2,3	11	M3.5-MC
611.0012.4 HM	12	64	130	8	6,7	10,7	11	IC-S11	2,3	11	M3.5-MC
614.0012.1 HM	12	34	100		9,0	13,8	11	IC-S14	4,0	14	M4-MC
614.0012.2 HM	12	45	110		9,0	13,8	11	IC-S14	4,0	14	M4-MC
614.0012.3 HM	12	64	130		9,0	13,8	11	IC-S14	4,0	14	M4-MC
614.0016.1 HM	16	34	100		9,0	13,8	15	IC-S14	4,0	14	M4-MC
614.0016.2 HM	16	45	110		9,0	13,8	15	IC-S14	4,0	14	M4-MC
614.0016.3 HM	16	64	130		9,0	13,8	15	IC-S14	4,0	14	M4-MC
614.0016.4 HM	16	75	145		9,0	13,8	15	IC-S14	4,0	14	M4-MC
616.0012.1 HM	12	40	130	11	10,2	15,7	11	IC-S16	4,3	16	M5-MC
616.0012.2 HM	12	56	130	11	10,2	15,7	11	IC-S16	4,3	16	M5-MC
616.0012.3 HM	12	80	150	11	10,2	15,7	11	IC-S16	4,3	16	M5-MC
616.0016.1 HM	16	40	130	11	10,2	15,7	15	IC-S16	4,3	16	M5-MC
616.0016.2 HM	16	56	130	11	10,2	15,7	15	IC-S16	4,3	16	M5-MC
616.0016.3 HM	16	80	150	11	10,2	15,7	15	IC-S16	4,3	16	M5-MC

Ersatzteile: Spannschrauben: siehe Tabelle  
*Spare parts: screw: see table*

Torx-Schlüssel: T8 ( M2.6-MC ) T10 ( M3.5-MC )  
*Torx screw driver: T15 ( M4-MC ) T20 ( M5-MC )*

## für Schneideinsätze

Typ IC-S08 / IC-S11 / IC-S14 / IC-S16

*use with insert type*

Typ IC-S08 / IC-S11 / IC-S14 / IC-S16

## Stahl- Klemmhalter

Toolholder (steel)

zum Stechdrehen,  
Ausdrehen und  
Gewindeschneiden  
(innen) ab Ø 7,8 mm

Grooving boring and  
threading (internal)  
bore Ø from 7,8 mm

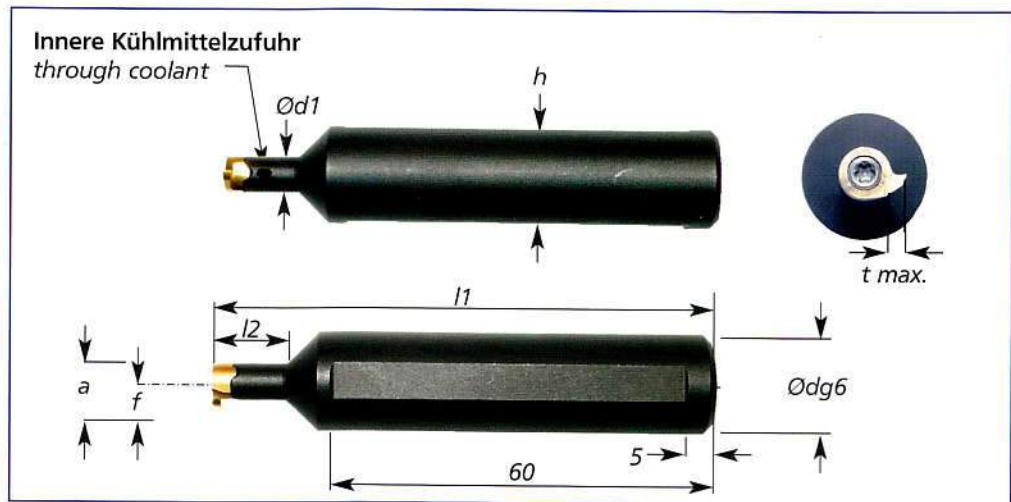

Bestellnummer part number	Ødg6	l2	l1	d1	f	a	h	für Schneidplatte use with insert	t max.	D min.	Spannschraube screw
608.0016.1 ST	16	12	80	6	4,8	7,8	15	IC-S08	1,0	8	M2.6-MC
611.0016.2 ST	16	16	97	8	6,7	10,7	15	IC-S11	2,3	11	M3.5-MC
614.0016.3 ST	16	18	100		9,0	13,8	15	IC-S14	4,0	14	M4-MC
616.0016.3 ST	16	22	100	11	10,2	15,7	15	IC-S16	4,3	16	M5-MC

Ersatzteile: Spanschrauben siehe Tabelle  
Spare parts: screw see table

Torx-Schlüssel Torx screw driver  
T 8 (M2.6-MC) T10 (M3.5-MC)  
T15 (M4-MC) T20 (M5-MC)

Auskräglänge L2 lang

overhead length L2 long

608.0016.1E ST	16	22	90	6	4,8	7,8	15	IC-S08	1,0	8	M2.6-MC
611.0016.2E ST	16	29	110	8	6,7	10,7	15	IC-S11	2,3	11	M3.5-MC
614.0016.3E ST	16	38	120		9,0	13,8	15	IC-S14	4,0	14	M4-MC
616.0016.3E ST	16	42	120	11	10,2	15,7	15	IC-S16	4,3	16	M5-MC

Ersatzteile: Spanschrauben siehe Tabelle  
Spare parts: screw see table

Torx-Schlüssel Torx screw driver  
T 8 (M2.6-MC) T10 (M3.5-MC)  
T15 (M4-MC) T20 (M5-MC)

## für Schneideinsätze

Typ IC-S08 / IC-S11 / IC-S14 / IC-S16

use with insert type

Typ IC-S08 / IC-S11 / IC-S14 / IC-S16

# INO-CUT Werkzeugsystem zur Bohrungsbearbeitung



*Tools for boring and profiling*

ab Bohrungsdurchmesser  
Ø 7,8 / 11,0 / 14,0 / 16,0 mm

Bore Ø from  
Ø 7,8 / 11,0 / 14,0 / 16,0 mm



mit innerer Kühlmittelzufuhr  
with through coolant

- **Hartmetall-Werkzeughalter**  
*Toolholder (hard metal)*
- **Stahl-Werkzeughalter**  
*Toolholder (steel)*
- **Stechdrehen (Innen)**  
*Grooving (internal)*
- **NC-Feindrehen (Innen)**  
*NC profiling (internal)*
- **Ausdrehen und Kopieren (Innen)**  
*Boring & copying (internal)*
- **Ausdrehen und Innenfreistichedrehen (Innen)**  
*Boring and profiling undercuts (internal)*
- **Rückwärtsdrehen (Innen)**  
*Boring by backward motion (internal)*
- **Fasen und Ausdrehen (Innen)**  
*Chamfering and boring (internal)*
- **Vorstechen und Fasen (Innen)**  
*Pregrooving and chamfering (internal)*
- **Gewindedrehen (Innen)**  
*Threading (internal)*
- **Axialstechen**  
*Face-grooving*



## Schneidplatten

Inserts

Stechdrehen (innen)  
ab Ø 8,0 / 11,0 mm

Grooving (internal)  
bore Ø from 8,0 / 11,0 mm

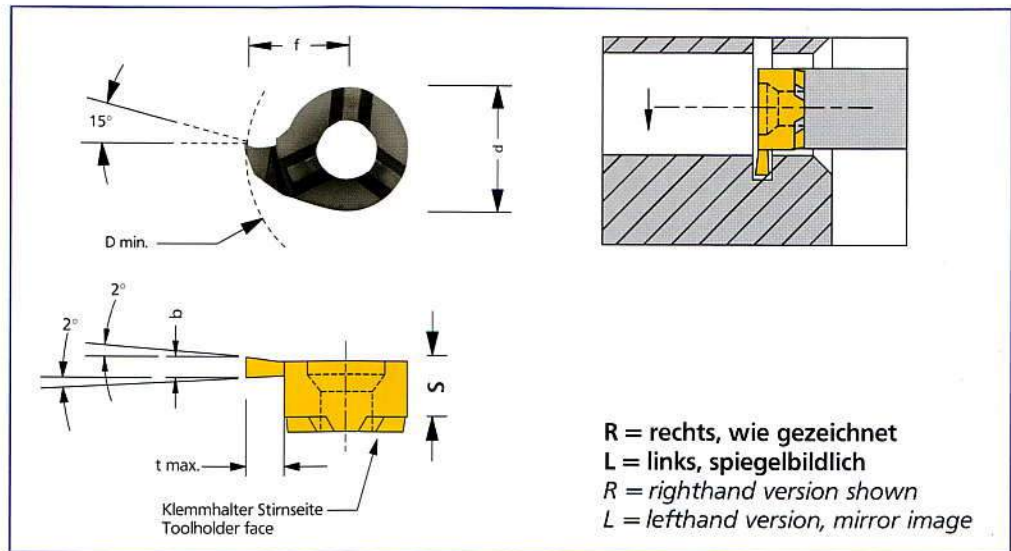

Bestellnummer Part number	Dmin.	Nutenbreite width of circlip	b+0,03	f	s	d	Klemmhalter Typ toolholder	t max.	HM-Sorte grade
------------------------------	-------	---------------------------------	--------	---	---	---	-------------------------------	--------	-------------------

Für Seeger – Ringnuten / circlip grooves

IC-S008.0070	8	0,70	0,73	4,8	3,3	6,0	608	1,0
IC-S008.0080	8	0,80	0,83	4,8	3,3	6,0	608	1,0
IC-S008.0090	8	0,90	0,93	4,8	3,3	6,0	608	1,0
IC-S008.0110	8	1,10	1,20	4,8	3,3	6,0	608	1,0
IC-S008.0130	8	1,30	1,40	4,8	3,3	6,0	608	1,0
IC-S008.0160	8	1,60	1,70	4,8	3,3	6,0	608	1,0

Stechdrehen allgemein / grooving

IC-S008.0100	8	-	1,00	4,8	3,3	6,0	608	1,0
IC-S008.0150	8	-	1,50	4,8	3,3	6,0	608	1,0
IC-S008.0200	8	-	2,00	4,8	3,3	6,0	608	1,0

Für Seeger – Ringnuten / circlips grooves

IC-S011.0070	11,0	0,70	0,73	6,7	4,2	8,0	611	1,2
IC-S011.0080	11,0	0,80	0,83	6,7	4,2	8,0	611	1,3
IC-S011.0090	11,0	0,90	0,93	6,7	4,2	8,0	611	1,5
IC-S011.0110	11,0	1,10	1,20	6,7	4,2	8,0	611	2,3
IC-S011.0130	11,0	1,30	1,40	6,7	4,2	8,0	611	2,3
IC-S011.0160	11,0	1,60	1,70	6,7	4,2	8,0	611	2,3

Stechdrehen allgemein / grooving

IC-S011.0100	11,0	-	1,00	6,7	4,2	8,0	611	2,3
IC-S011.0150	11,0	-	1,50	6,7	4,2	8,0	611	2,3
IC-S011.0200	11,0	-	2,00	6,7	4,2	8,0	611	2,3
IC-S011.0250	11,0	-	2,50	6,7	4,2	8,0	611	2,3
IC-S011.0300	11,0	-	3,00	6,7	4,2	8,0	611	2,3

TIALN



**Ausführung R oder L angeben / State R or L version**

Abmessungen in mm / Dimensions in mm

für Klemmhalter 608 und 611 Seite 5 + 6

for use with toolholder 608 / 611 page 5 + 6



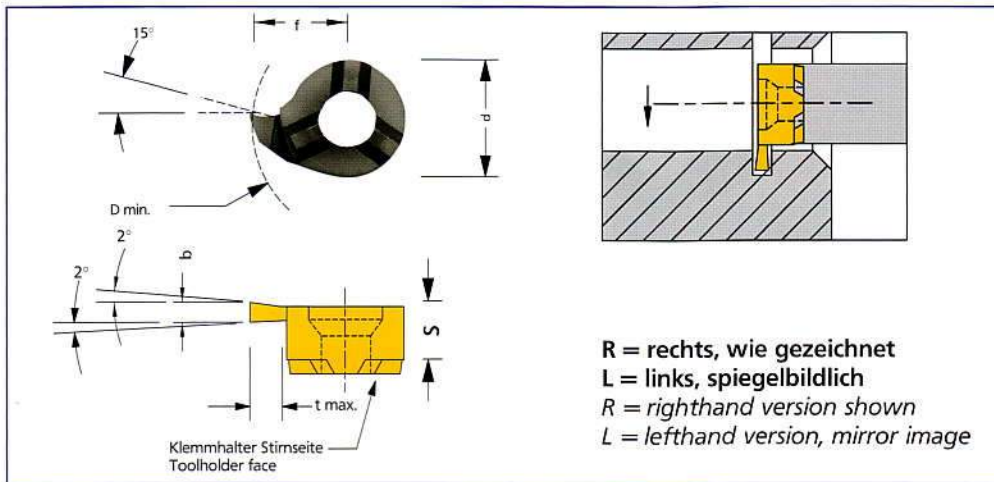

## Schneidplatten

Inserts

**Stechdrehen (innen)**  
**ab Ø 14,0 und 16,0 mm**  
*Grooving (internal)*  
*bore Ø from 14,0 / 16,0 mm*

R = rechts, wie gezeichnet  
 L = links, spiegelbildlich  
 R = righthand version shown  
 L = lefthand version, mirror image

Bestellnummer Part number	Dmin.	Nutenbreite width of circlip	b+0,03	f	s	d	Klemmhalter Typ toolholder	t max.	HM-Sorte grade
<b>Für Seeger – Ringnuten / circlip grooves</b>									
IC-S014.0070	14,0	0,70	0,73	9,0	5,3	9,0	614	1,2	
IC-S014.0080	14,0	0,80	0,83	9,0	5,3	9,0	614	1,3	
IC-S014.0090	14,0	0,90	0,93	9,0	5,3	9,0	614	1,5	
IC-S014.0110	14,0	1,10	1,20	9,0	5,3	9,0	614	4,0	
IC-S014.0130	14,0	1,30	1,40	9,0	5,3	9,0	614	4,0	
IC-S014.0160	14,0	1,60	1,70	9,0	5,3	9,0	614	4,0	
<b>Stechdrehen allgemein / grooving</b>									
IC-S014.0150	14,0	-	1,50	9,0	5,3	9,0	614	4,0	
IC-S014.0200	14,0	-	2,00	9,0	5,3	9,0	614	4,0	
IC-S014.0250	14,0	-	2,50	9,0	5,3	9,0	614	4,0	
IC-S014.0300	14,0	-	3,00	9,0	5,3	9,0	614	4,0	
<b>Für Seeger – Ringnuten / circlips grooves</b>									
IC-S016.0070	16,0	0,70	0,73	10,2	5,4	11,0	616	1,2	
IC-S016.0080	16,0	0,80	0,83	10,2	5,4	11,0	616	1,3	
IC-S016.0090	16,0	0,90	0,93	10,2	5,4	11,0	616	1,5	
IC-S016.0110	16,0	1,10	1,20	10,2	5,4	11,0	616	4,3	
IC-S016.0130	16,0	1,30	1,40	10,2	5,4	11,0	616	4,3	
IC-S016.0160	16,0	1,60	1,70	10,2	5,4	11,0	616	4,3	
<b>Stechdrehen allgemein / grooving</b>									
IC-S016.0150	16,0	-	1,50	10,2	5,4	11,0	616	4,3	
IC-S016.0200	16,0	-	2,00	10,2	5,4	11,0	616	4,3	
IC-S016.0250	16,0	-	2,50	10,2	5,4	11,0	616	4,3	
IC-S016.0300	16,0	-	3,00	10,2	5,4	11,0	616	4,3	
IC-S016.0350	16,0	-	3,50	10,2	5,4	11,0	616	4,3	
IC-S016.0400	16,0	-	4,00	10,2	5,4	11,0	616	4,3	

TIALN



**Ausführung R oder L angeben / State R or L version**

Abmessungen in mm / Dimensions in mm

**für Klemmhalter 614 und 616 Seite 5 + 6**

for use with toolholder 614 / 616 page 5 + 6

# INO-CUT Werkzeugsystem zur Bohrungsbearbeitung

Tools for boring and profiling

## Schneidplatten

Inserts

NC-Feindreihen (innen)  
ab Ø 8,0 / 11,0 / 14,0 /  
16,0 mm

NC-profiling (internal)  
bore Ø from 8,0 / 11,0 / 14,0 /  
16,0 mm

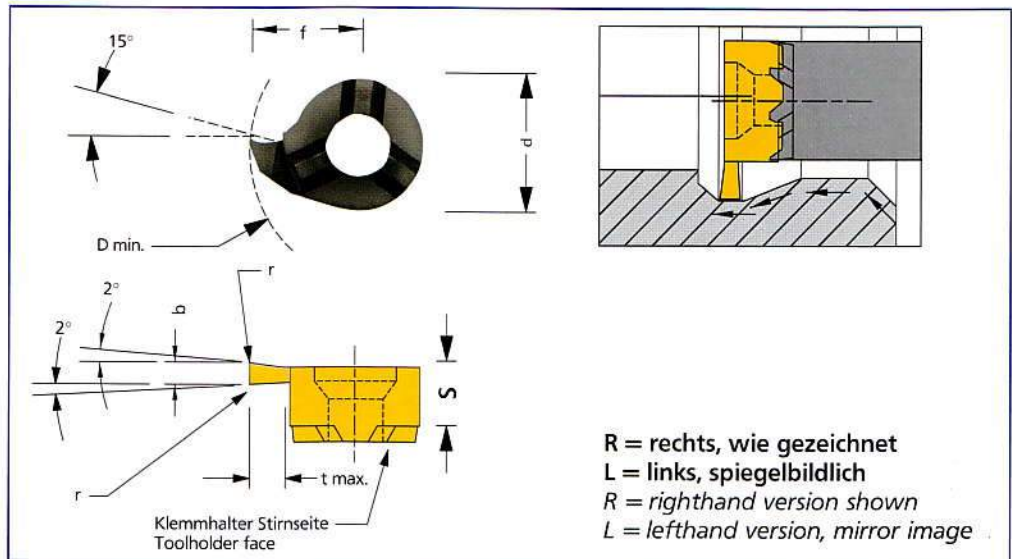

Bestellnummer part number	Dmin.	b+0.05	r	f	s	d	Klemmhalter Typ Toolholder type	t max.	HM Sorte grade
IC-S08.150.02	8,0	1,5	0,2	4,8	3,3	6,0	608	1,0	TIALN
IC-S11.200.02	11,0	2,0	0,2	6,7	4,2	8,0	611	2,3	
IC-S14.200.02	14,0	2,0	0,2	9,0	5,3	9,0	614	4,0	
IC-S16.200.02	16,0	2,0	0,2	10,2	5,4	11,0	616	4,3	



**Ausführung R oder L angeben / State R or L version**

Abmessungen in mm / Dimensions in mm

für Klemmhalter 608 / 611 / 614 / 616

Seite 5 + 6

for use with toolholder 608 / 611 / 614 / 616

page 5 + 6

# INO-CUT Werkzeugsystem zur Bohrungsbearbeitung



Tools for boring and profiling

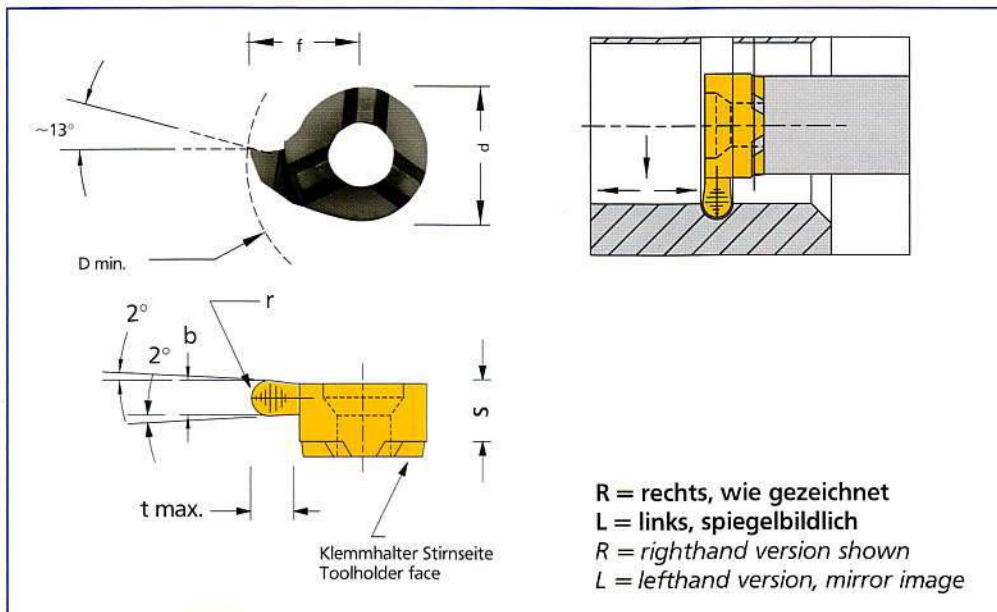

## Schneidplatten Vollradius

Inserts / full nose radius

Stechdrehen (innen)  
ab Ø 8,0 / 11,0 / 14,0 /  
16,0 mm

Grooving (internal)  
bore Ø from 8,0 / 11,0 / 14,0 /  
16,0 mm

Bestellnummer Part number	Dmin.	b+0.05	r	f	s	d	Klemmhalter Typ toolholder type	t max.	HM Sorte grade
IC-S08.008R04	8,0	0,8	0,4	4,8	3,3	6,0	608	1,0	TIALN
IC-S08.012R06	8,0	1,2	0,6	4,8	3,3	6,0	608	1,0	
IC-S08.018R09	8,0	1,8	0,9	4,8	3,3	6,0	608	1,0	
IC-S11.008R04	11,0	0,8	0,4	6,7	4,2	8,0	611	2,3	
IC-S11.012R06	11,0	1,2	0,6	6,7	4,2	8,0	611	2,3	
IC-S11.018R09	11,0	1,8	0,9	6,7	4,2	8,0	611	2,3	
IC-S11.020R10	11,0	2,0	1,0	6,7	4,2	8,0	611	2,3	
IC-S11.030R15	11,0	3,0	1,5	6,7	4,2	8,0	611	2,3	
IC-S14.012R06	14,0	1,2	0,6	9,0	4,0	9,0	614	4,0	
IC-S14.018R09	14,0	1,8	0,9	9,0	4,0	9,0	614	4,0	
IC-S14.020R10	14,0	2,0	1,0	9,0	4,0	9,0	614	4,0	
IC-S14.022R11	14,0	2,2	1,1	9,0	4,0	9,0	614	4,0	
IC-S14.030R15	14,0	3,0	1,5	9,0	4,0	9,0	614	4,0	
IC-S16.018R09	16,0	1,8	0,9	10,2	5,4	11,0	616	4,3	
IC-S16.022R11	16,0	2,2	1,1	10,2	5,4	11,0	616	4,3	
IC-S16.030R15	16,0	3,0	1,5	10,2	5,4	11,0	616	4,3	
IC-S16.040R20	16,0	4,0	2,0	10,2	5,4	11,0	616	4,3	



Ausführung R oder L angeben / State R or L version

Abmessungen in mm / Dimensions in mm

für Klemmhalter 608 / 611 / 614 / 616

Seite 5 + 6

for use with toolholder 608 / 611 / 614 / 616

page 5 + 6

## Schneidplatten

Inserts

**Ausdrehen und kopieren (Innen)**  
ab  $\varnothing$  7,8 / 11,0 / 14,0 / 16,0 mm

*Boring and copying (internal)*  
bore  $\varnothing$  from 7,8 / 11,0 / 14,0 / 16,0 mm

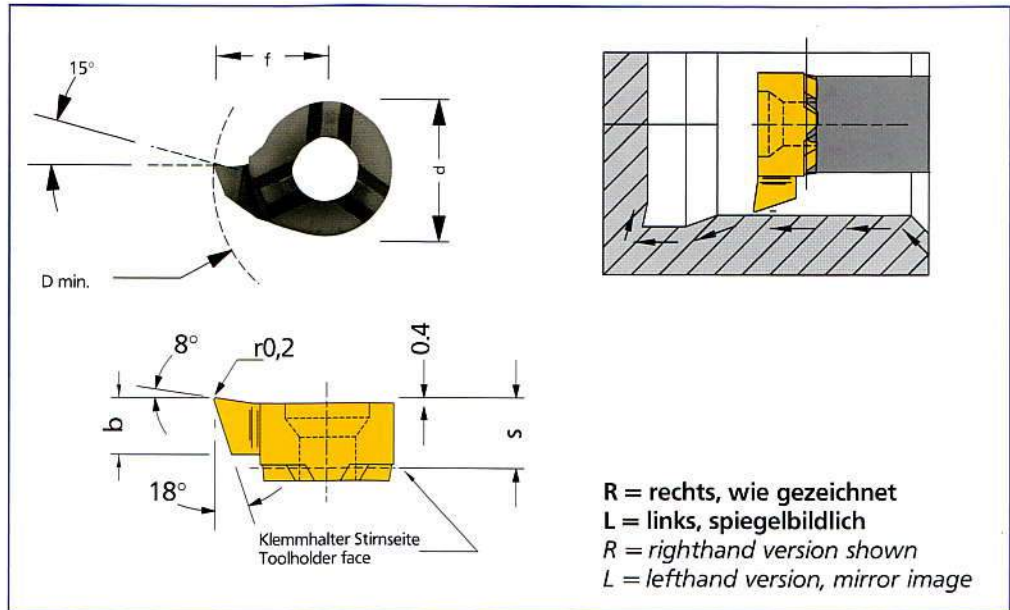

Bestellnummer part number	Dmin.	b	f	s	d	Klemmhalter Typ toolholder type	Ecken-Radius corner-radius	HM Sorte grade
IC-S08.1846.02	7,8	3,3	4,65	3,5	6,0	608	0,2	TIALN
IC-S11.1855.02	9,8	3,9	5,5	4,2	8,0	611	0,2	
IC-S11.1867.02	11,0	3,9	6,7	4,2	8,0	611	0,2	
IC-S14.1867.02	13,8	5,0	8,7	5,1	9,0	614	0,2	
IC-S16.1897.02	15,5	5,0	9,7	5,4	11,0	616	0,2	



**Ausführung R oder L angeben / State R or L version**

Abmessungen in mm / Dimensions in mm

für Klemmhalter 608 / 611 / 614 / 616

Seite 5 + 6

for use with toolholder 608 / 611 / 614 / 616

page 5 + 6

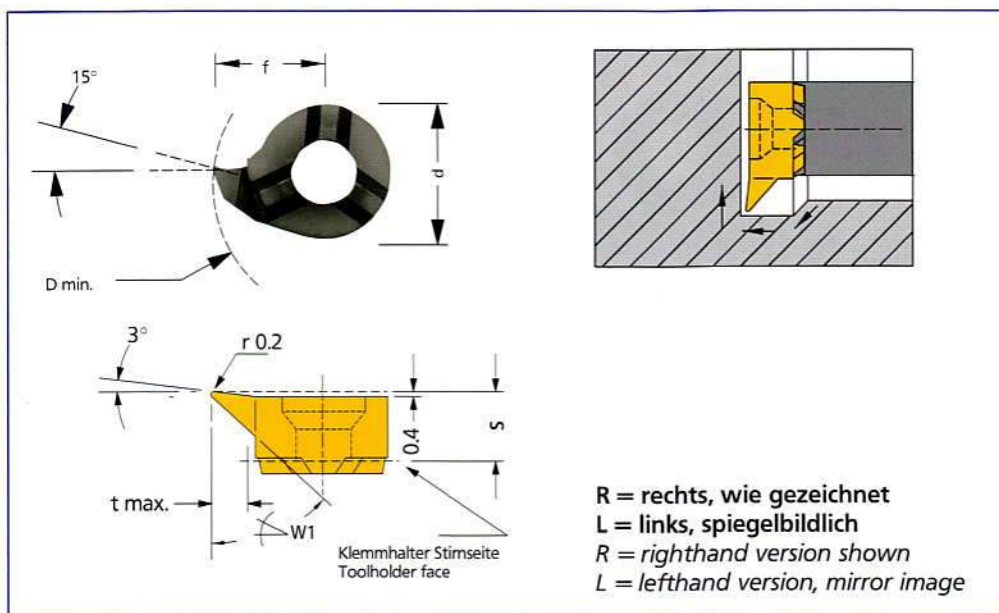

## Schneidplatten

Inserts

**Ausdrehen, Innenfreistiche (DIN 509) und kopieren Ø 7,8 / 11,0 / 13,7 mm**

*Boring and profiling undercuts (DIN 509) and copying bore Ø from 7,8 / 11,0 / 13,7 mm*

Bestellnummer part number	Dmin.	t max.	$\angle$ w1	f	s	Klemmhalter Typ Toolholder type	d	Ecken-Radius corner-radius	HM Sorte grade
<b>Ausdrehen und Innenfreistiche (DIN 509) / Boring and profiling undercuts (DIN 509)</b>									
IC-S08.4746.02	7,8	1,2	47°	4,65	3,5	608	6,0	0,2	
IC-S11.4767.02	11,0	2,3	47°	6,7	4,2	611	8,0	0,2	
IC-S14.4787.02	13,7	3,0	47°	8,7	5,3	614	9,0	0,2	
<b>Kopieren / copying</b>									
IC-S08.2555.02	7,8	1,0	30°	4,65	3,5	608	6,0	0,2	
IC-S11.2755.02	11,0	2,3	30°	6,7	4,2	611	8,0	0,2	
IC-S14.3555.02	13,7	4,0	30°	8,7	5,3	614	9,0	0,2	
IC-S14.4055.02	13,7	4,3	30°	10,2	5,4	614	9,0	0,2	

TIALN



**Ausführung R oder L angeben / State R or L version**

Abmessungen in mm / Dimensions in mm

für Klemmhalter 608 / 611 / 614

Seite 5 + 6

for use with toolholder 608 / 611 / 614

page 5 + 6

## Schneidplatten

Inserts

**Rückwärtsdrehen  
(innen) ab Ø 7,8 / 11,0 /  
13,8 mm**

*Boring by backward motion  
(internal) bore Ø from 7,8 /  
11,0 / 13,8 mm*

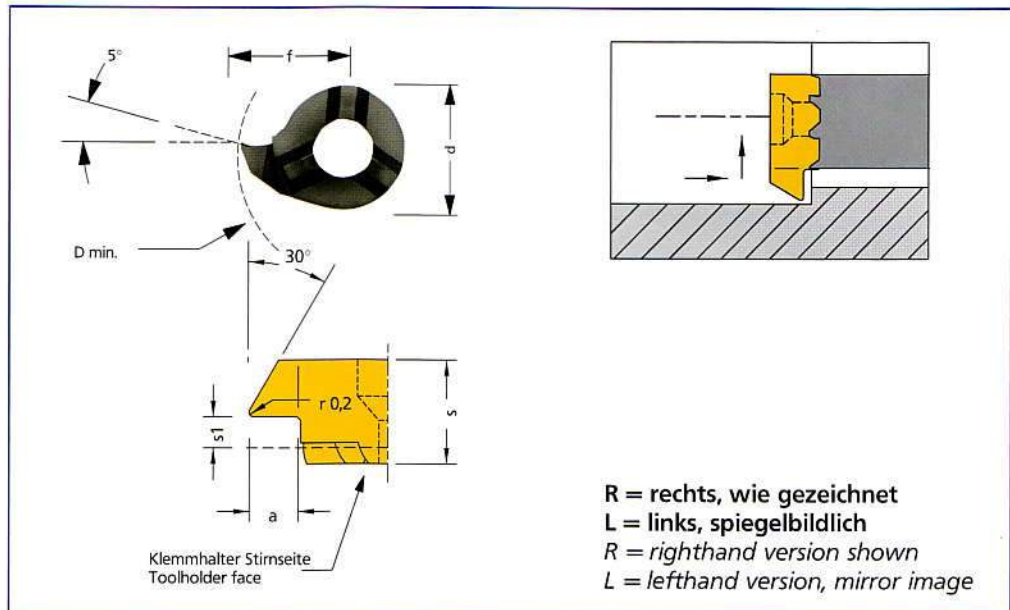

Bestellnummer part number	Dmin.	Ecken-Radius corner radius	f	s1	s	d	a	Klemmhalter Typ	HM Sorte grade
IC-S08.3046.02	7,8	0,2	4,65	1,0	3,5	6,0	1,3	608	TIALN
IC-S11.3067.02	11,0	0,2	6,7	1,6	4,3	8,0	2,3	611	
IC-S14.3087.02	13,8	0,2	8,7	2,4	5,4	9,0	3,5	614	



**Ausführung R oder L angeben / State R or L version**

Abmessungen in mm / Dimensions in mm

für Klemmhalter 608 / 611 / 614

Seite 5 + 6

for use with toolholder 608 / 611 / 614

page 5 + 6

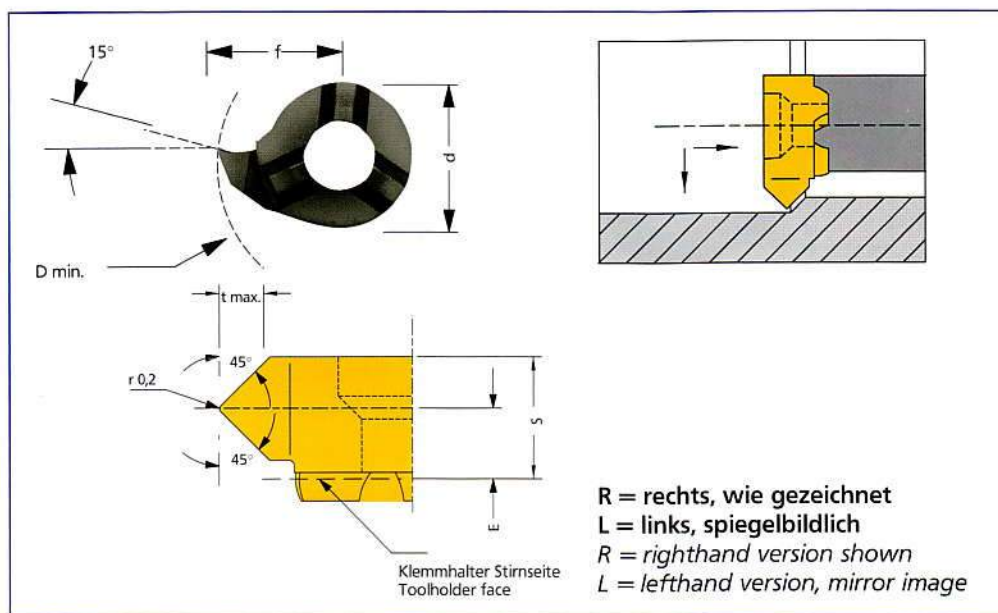

## Schneidplatten

*Inserts*

**Fasen und Ausdrehen,  
 (Innen) ab Ø 8,0 / 11,0 /  
 14,0 mm**

*Chamfering and profiling  
 (internal) bore Ø from 8,0 /  
 11,0 / 14,0 mm*

R = rechts, wie gezeichnet  
 L = links, spiegelbildlich  
 R = righthand version shown  
 L = lefthand version, mirror image

Bestellnummer <i>part number</i>	Dmin.	Ecken-Radius <i>corner radius</i>	f	E	s	d	Klemhalter Typ <i>toolholder type</i>	t max.	HM Sorte <i>grade</i>
IC-S08.4545.02	8,0	0,2	4,8	1,8	3,5	6,0	608	1,4	TIALN
IC-S11.4545.02	11,0	0,2	6,7	2,2	4,3	8,0	611	1,5	
IC-S14.4545.02	14,0	0,2	9,0	2,8	5,4	9,0	614	1,5	



**Ausführung R oder L angeben / State R or L version**

*Abmessungen in mm / Dimensions in mm*

**für Klemhalter 608 / 611 / 614**

**Seite 5 + 6**

*for use with toolholder 608 / 611 / 614*

*page 5 + 6*

## Schneidplatten

Inserts

Vorstechen und Fasen  
ab  $\varnothing$  8,0 / 11,0 / 14,0 /  
16,0 mm

Pregrooving and chamfering  
bore  $\varnothing$  from 8,0 / 11,0 / 14,0 /  
16,0 mm

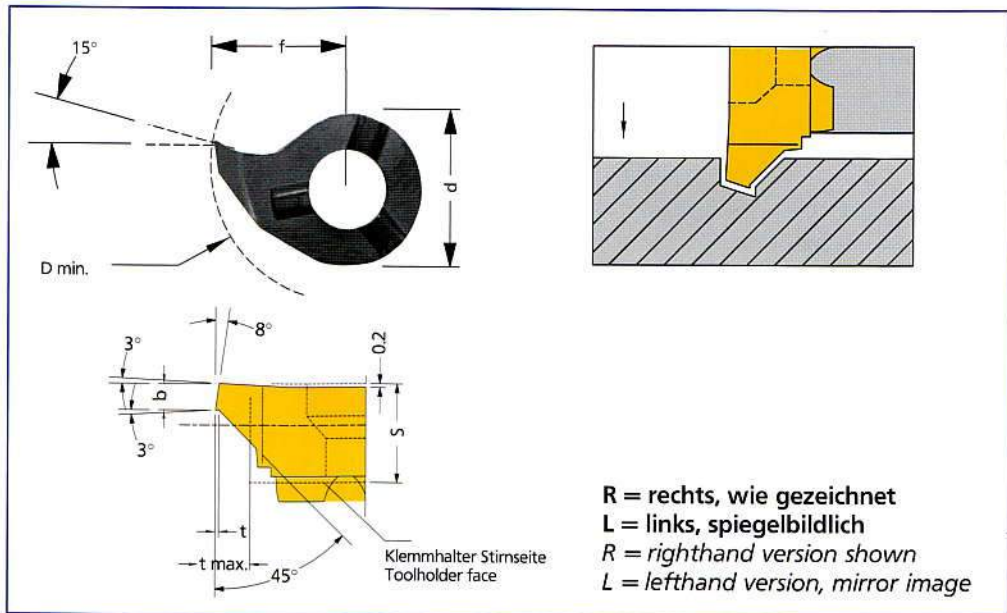

Bestellnummer part number	Dmin.	b	f	t	s	d	Klemmhalter Typ toolholder type	t max.	HM Sorte grade
IC-S08.0810.45	8,0	1,0	4,8	0,2	3,3	6,0	608	1,0	TIALN
IC-S11.0810.45	11,0	1,0	6,7	0,2	4,2	8,0	611	1,5	
IC-S14.0815.45	14,0	1,0	9,0	0,2	5,3	9,0	614	1,5	
IC-S16.0815.45	16,0	1,0	10,2	0,2	5,4	11,0	616	1,5	



Ausführung R oder L angeben / State R or L version

Abmessungen in mm / Dimensions in mm

für Klemmhalter 608 / 611 / 614

Seite 5 + 6

for use with toolholder 608 / 611 / 614

page 5 + 6



# INO-CUT Werkzeugsystem zur Bohrungsbearbeitung

Tools for boring and profiling

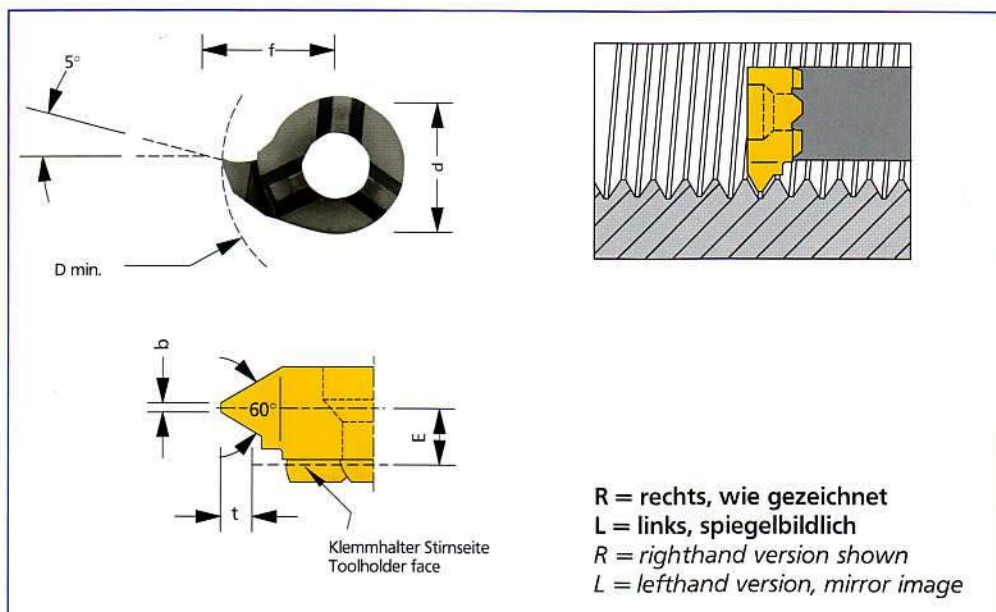

## Schneidplatten

Inserts

**Gewindedrehen  
(Innen) ab Ø 8,0 / 11,0 /  
14,0 / 16,0 mm**

*Threading (internal)  
bore Ø from 8,0 / 11,0 /  
14,0 / 16,0 mm*

**Metrisches Gewinde  
ISO Teilprofil**

*Metric thread  
ISO partial profile*

Bestellnummer part number	Dmin.	Steigung pitch	t	f	E	s	b	Klemmhalter Typ toolholder type	d	HM Sorte grade	
<b>Regel-Gewinde / standard thread</b>											
IC-S08.0815.01	8,0	1,5/1,75	0,95	4,8	2,5	3,5	0,18	608	6,0	TIALN	
IC-S11.1020.01	11,0	2,0	1,08	6,7	3,0	4,3	0,25	611	8,0		
IC-S11.1325.01	11,0	2,5	1,35	6,7	3,0	4,3	0,31	611	8,0		
IC-S14.1020.01	14,0	2,0	1,08	9,0	4,2	5,4	0,25	614	9,0		
IC-S14.1325.01	14,0	2,5	1,35	9,0	4,7	5,4	0,31	614	9,0		
IC-S16.1325.01	16,0	2,5	1,35	10,2	4,2	5,5	0,31	616	11,0		
<b>Fein-Gewinde / fine thread</b>											
IC-S08.0205.01	8,0	0,5/0,75	0,43	4,8	2,7	3,5	0,06	608	6,0		
IC-S08.0510.01	8,0	1,0/1,25	0,70	4,8	2,7	3,5	0,12	608	6,0		
IC-S11.0205.01	11,0	0,5/0,75	0,75	6,7	3,5	4,3	0,06	611	8,0		
IC-S11.0510.01	11,0	1,0	0,55	6,7	3,5	4,3	0,12	611	8,0		
IC-S11.0815.01	11,0	1,5	0,81	6,7	3,5	4,3	0,18	611	8,0		
IC-S14.0510.01	14,0	1,0	0,55	9,0	4,7	5,4	0,12	614	9,0		
IC-S14.0815.01	14,0	1,5	0,81	9,0	4,5	5,4	0,18	614	9,0		
IC-S16.0510.01	16,0	1,0	0,55	10,2	4,7	5,5	0,12	616	11,0		
IC-S16.0815.01	16,0	1,5	0,81	10,2	4,5	5,5	0,18	616	11,0		
IC-S16.1020.01	16,0	2,0	1,08	10,2	4,2	5,5	0,25	616	11,0		

**Ausführung R oder L angeben / State R or L version**

Abmessungen in mm / Dimensions in mm



für Klemmhalter 608 / 611 / 614 / 616 Seite 5 + 6

for use with toolholder 608 / 611 / 614 / 616 page 5 + 6

## Schneidplatten

Inserts

**Gewindedrehen  
(Innen) ab Ø 11,0 /  
14,0 / 16,0 mm**

Threading (internal) bore Ø  
from 11,0 / 14,0 / 16,0 mm

**Metrisches Gewinde  
ISO Vollprofil**

Metric thread  
ISO full profile

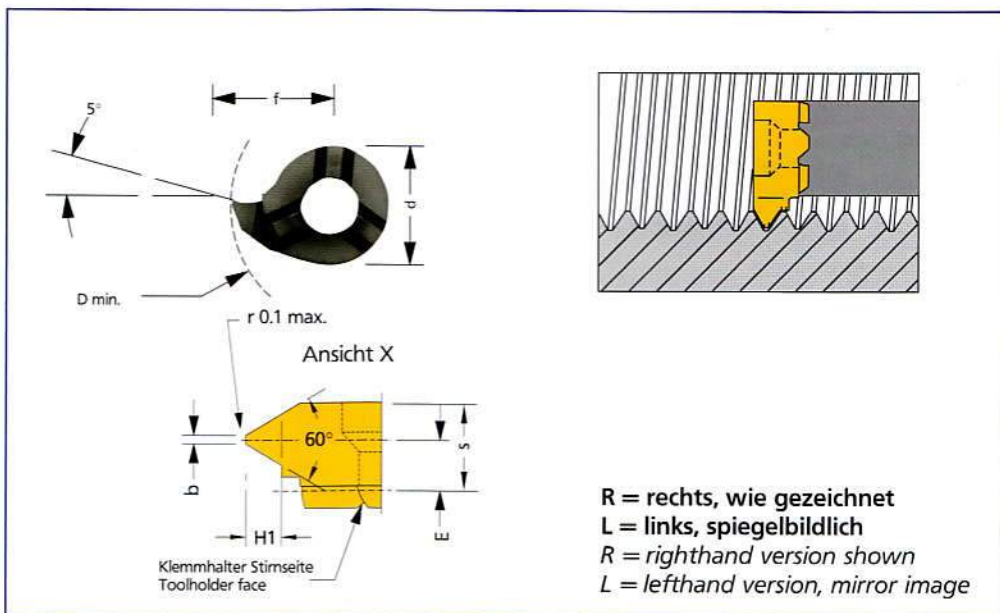

Bestellnummer part number	Dmin.	Steigung pitch	H1	f	E	s	b	Klemmhalter Typ toolholder type	d	HM Sorte grade	
<b>Regel-Gewinde / standard thread</b>											
IC-S11.1020.02	11,0	2,0	1,08	6,7	3,2	4,3	0,25	611	8,0	TIALN	
IC-S11.1325.02	11,0	2,5	1,35	6,7	3,0	4,3	0,31	611	8,0		
IC-S11.1630.02	11,0	3,0	1,62	6,7	2,9	4,3	0,37	611	8,0		
IC-S14.1020.02	14,0	2,0	1,08	9,0	4,2	5,4	0,25	614	9,0		
IC-S14.1325.02	14,0	2,5	1,35	9,0	4,7	5,4	0,31	614	9,0		
IC-S16.1325.02	16,0	2,5	1,35	10,2	4,2	5,5	0,31	616	11,0		
IC-S16.1630.02	16,0	3,0	1,62	10,2	4,0	5,5	0,37	616	11,0		
IC-S16.1835.02	16,0	3,5	1,89	10,2	3,8	5,5	0,43	616	11,0		
IC-S16.2140.02	16,0	4,0	2,16	10,2	3,6	5,5	0,50	616	11,0		
<b>Fein - Gewinde / fine - thread</b>											
IC-S11.0510.02	11,0	1,0	0,54	6,7	3,5	4,3	0,12	611	8,0		
IC-S11.0815.02	11,0	1,5	0,81	6,7	3,5	4,3	0,18	611	8,0		
IC-S14.0205.02	14,0	0,5	0,27	9,0	0,5	5,4	0,06	614	9,0		
IC-S14.0510.02	14,0	1,0	0,54	9,0	3,5	5,4	0,12	614	9,0		
IC-S14.0815.02	14,0	1,5	0,81	9,0	3,3	5,4	0,18	614	9,0		
IC-S16.0510.02	16,0	1,0	0,54	10,2	4,7	5,5	0,12	616	11,0		
IC-S16.0815.02	16,0	1,5	0,81	10,2	4,5	5,5	0,18	616	11,0		
IC-S16.1020.02	16,0	2,0	1,08	10,2	4,2	5,5	0,25	616	11,0		

**Ausführung R oder L angeben / State R or L version**

Abmessungen in mm / Dimensions in mm

für Klemmhalter 611 / 614 / 616

Seite 5 + 6

for use with toolholder 611 / 614 / 616

page 5 + 6

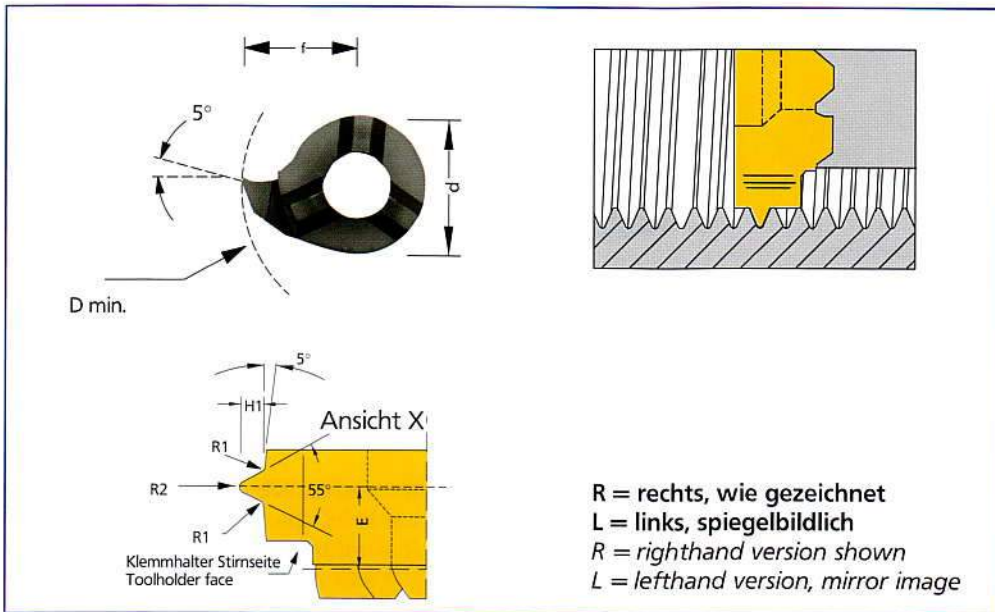

## Schneidplatten

*Inserts*

**Gewindedrehen  
(Innen) ab Ø 11,0 und  
16,0 mm**

*Threading (internal)  
bore Ø from 11,0 and  
16,0 mm*

**Whitworth  
Vollprofil**

*Whitworth  
full profile*

Bestellnummer <i>part number</i>	Dmin. <i>pitch</i>	Steigung <i>pitch</i>	H1	Gg/Zoll	f	E	s	R1	R2	Klemhalter Typ <i>toolholder type</i>	d	HM Sorte <i>grade</i>
IC-S11.0813.19	11,0	1,337	0,85	19	6,7	2,7	4,3	0,18	0,18	611	8,0	TIALN
IC-S11.1118.14	11,0	1,814	1,16	14	6,7	3,0	4,3	0,24	0,24	611	8,0	
IC-S16.1118.14	16,0	1,814	1,16	14	10,2	3,9	5,5	0,24	0,24	616	11,0	
IC-S16.1423.11	16,0	2,309	1,48	11	10,2	3,5	5,5	0,31	0,31	616	11,0	



**Ausführung R oder L angeben / State R or L version**

*Abmessungen in mm / Dimensions in mm*

**für Klemhalter 611 / 616**

**Seite 5 + 6**

*for use with toolholder 611 / 616  
page 5 + 6*

## Schneidplatten

Inserts

**Gewindedrehen  
(Innen) ab Ø 11,0 und  
16,0 mm**

*Threading (internal)  
bore Ø from 11,0 and  
16,0 mm*

**Trapez-Gewinde  
Trapezoidal thread**

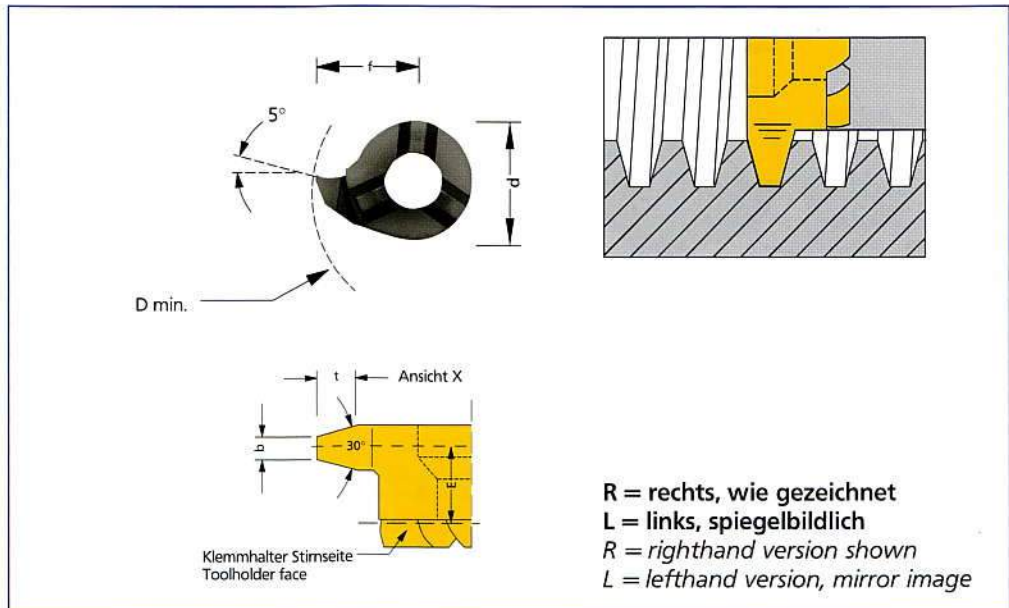

Bestellnummer part number	Dmin.	Steigung pitch	t	f	E	s	b	Klemmhalter Typ toolholder type	d	HM Sorte grade
IC-S11.1015.01	11,0	1,5	0,9	6,7	3,7	4,3	0,47	611	8,0	TIALN
IC-S11.1220.01	11,0	2,0	1,25	6,7	3,5	4,3	0,60	611	8,0	
IC-S11.1730.01	11,0	3,0	1,75	6,7	3,2	4,3	0,96	611	8,0	
IC-S16.1220.01	16,0	2,0	1,25	10,2	4,5	5,5	0,60	616	11,0	
IC-S16.1730.01	16,0	3,0	1,75	10,2	4,3	5,5	0,96	616	11,0	
IC-S16.2240.01	16,0	4,0	2,25	10,2	4,0	5,5	1,33	616	11,0	

**Ausführung R oder L angeben / State R or L version**

Abmessungen in mm / Dimensions in mm

für Klemmhalter 611 / 616

Seite 5 + 6

for use with toolholder 611 / 616  
page 5 + 6

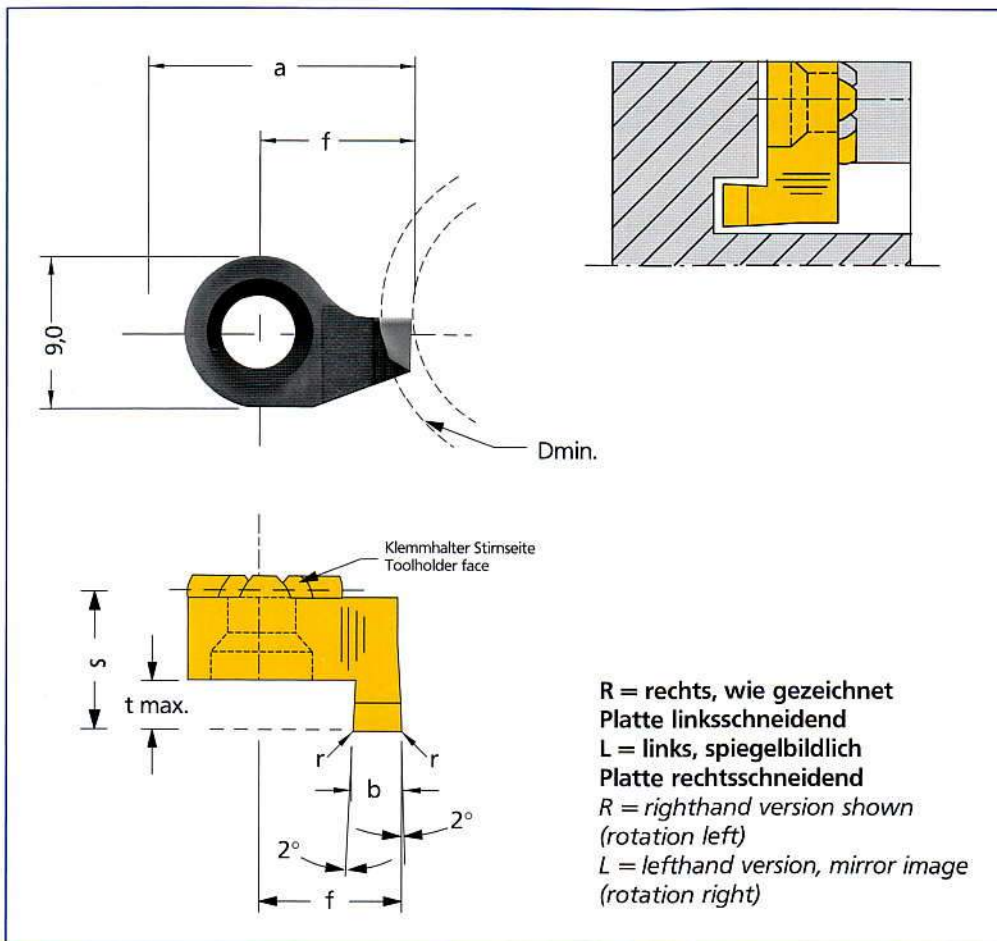

## Schneidplatten

Inserts

**Axialstechen**  
**ab Ø 12,0 mm**

*Face-grooving*  
*bore Ø from 12,0 mm*

R = rechts, wie gezeichnet  
 Platte linksschneidend  
 L = links, spiegelbildlich  
 Platte rechtsschneidend  
 R = righthand version shown  
 (rotation left)  
 L = lefthand version, mirror image  
 (rotation right)

Bestellnummer Part number	Dmin.	b+0,03	a	f	r	s	Klemmhalter Typ toolholder	t max.	HM-Sorte grade
IC-S014.1210.00	12,0	1,0	11,5	7,0	-	8,3	614	1,5	
IC-S014.1215.02	12,0	1,5	12,0	7,5	0,2	8,3	614	2,5	
IC-S014.1220.02	12,0	2,0	12,5	8,0	0,2	8,3	614	3,0	
IC-S014.1225.02	12,0	2,5	13,0	8,5	0,2	8,3	614	3,0	
IC-S014.1230.02	12,0	3,0	13,5	9,0	0,2	8,3	614	3,0	
IC-S014.1220.52	12,0	2,0	12,5	8,0	0,2	10,3	614	5,0	
IC-S014.1225.52	12,0	2,5	13,0	8,5	0,2	10,3	614	5,0	
IC-S014.1230.52	12,0	3,0	13,5	9,0	0,2	10,3	614	5,0	



**Ausführung R oder L angeben / State R or L version**

Abmessungen in mm / Dimensions in mm

**für Klemmhalter 614**

**Seite 5 + 6**

*for use with toolholder 614*

*page 5 + 6*

## Schneidplatten

Inserts

**Axialstechen**  
ab  $\varnothing$  14,0 mm

Face-grooving  
bore  $\varnothing$  from 14,0 mm

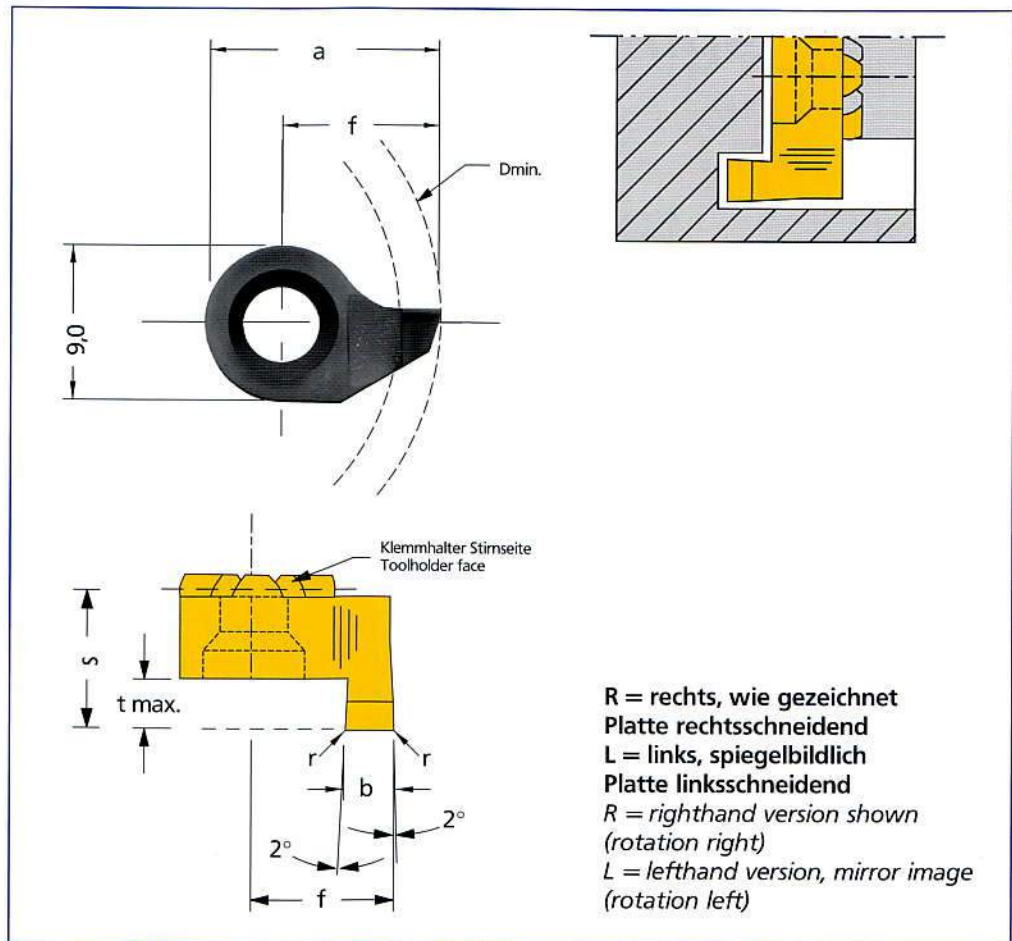

Bestellnummer Part number	Dmin.	b+0,03	a	f	r	s	Klemmhalter Typ toolholder	t max.	HM-Sorte grade
IC-S014.1410.00	14,0	1,0	13,5	9,0	-	8,3	614	1,5	
IC-S014.1415.02	14,0	1,5	13,5	9,0	0,2	8,3	614	2,5	
IC-S014.1420.02	14,0	2,0	13,5	9,0	0,2	8,3	614	3,0	
IC-S014.1425.02	14,0	2,5	13,5	9,0	0,2	8,3	614	3,0	
IC-S014.1430.02	14,0	3,0	13,5	9,0	0,2	8,3	614	3,0	
IC-S014.1420.52	14,0	2,0	13,5	9,0	0,2	10,3	614	5,0	
IC-S014.1425.52	14,0	2,5	13,5	9,0	0,2	10,3	614	5,0	
IC-S014.1430.52	14,0	3,0	13,5	9,0	0,2	10,3	614	5,0	

**Ausführung R oder L angeben / State R or L version**

Abmessungen in mm / Dimensions in mm

für Klemmhalter 614

Seite 5 + 6

for use with toolholder 614

page 5 + 6

# INO-CUT Technologiedaten – Schnittgeschwindigkeits-Richtwerte (m/min)



## Cutting data for INO-CUT – Cutting Speed-guideline (m/min)

zu bearbeitender Werkstoff Material to be machined		Brinell – Härte hardness ( HB )	AL41F Beschichtung Coated
Kohlenstoffstahl Carbon steel	1.0711 9S20	140	80 – 200
	1.0037 ST37	180	
	1.0050 ST50	200	
Legierter Stahl Alloyed steel	1.0070 ST70	180	80 – 200
	1.7131 16MnCr5	280	
	1.7218 25CrMo4	350	
Hochlegierter Stahl High alloyed steel	1.2842 90MnCrV8	200	80 – 160
	1.7225 42CrMo4V		
	X40CrMo4V		
Rostfreier Stahl Stainless steel	1.4057 20CrNi17 2	200	80 – 160
	1.4301 X5CrNi18 10	200	
	1.4104 X12CrMoS17	180	
Stahlguss Cast steel	unlegiert / unalloyed	180	90 – 160
	legiert / alloyed	220	
Temperguss Tempered steel	0.8035 GTW35	125	60 – 180
	0.8155 GTS 55	220	
Grauguss Cast iron	0.6020 GG20	180	60 – 180
	0.6040 GG40	250	
Kugelgraphitguss Spendal cast iron	0.7040 GGG40	160	60 – 180
	0.7070 GGG70	250	
Warmfeste Legierungen – ( Nickel o. Kobaldlegierungen ) Heat Resistant – Nickel or cobol alloys	geglüht / annealed	250	30 – 80
Al – Legierungen Aluminium alloy castings	nicht vergütbar not hardenable	30 – 80	200 – 800
	vergütbar/hardenable	80 – 120	100 – 700
AL – Guss Legierungen Aluminium – cast - alloys	nicht vergütbar not hardenable	80	200 – 800
	vergütbar hardenable	100	100 – 700
Kupfer und Messing Bronze – brass – alloys			80 – 700

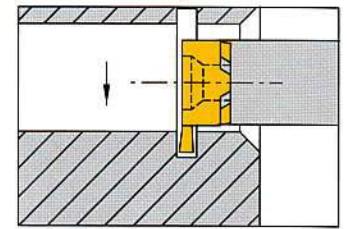

Vorschubsbereich f mm/U  
Feed rates f mm/rev.  
0.01 – 0.03

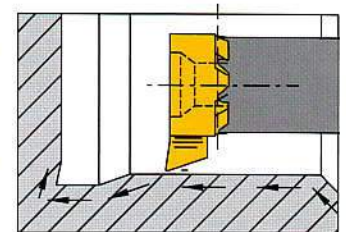

Vorschubsbereich f mm/U  
Feed rates f mm/rev.  
0.03 – 0.10

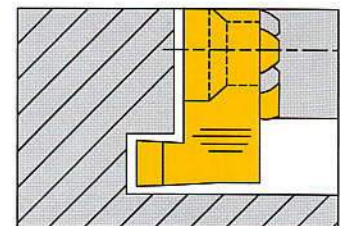

Vorschubsbereich f mm/U  
Feed rates f mm/rev.  
0.01 – 0.03

Für Nass- und Trockenbearbeitung ist unsere Schneidstoff-Sorte AL41F bestens geeignet.

For wet- and dry machining our grade AL41F is the most suitable.

Irrtümer, Druckfehler und technische Änderungen vorbehalten.  
Subject to technical changes. No responsibility for errors or printers errors accepted.

# Otto Dieterle Spezialwerkzeuge GmbH

Predigerstr. 56  
78628 Rottweil, Germany

Tel.: +49 (0) 741 / 9 42 05 - 0  
Fax: +49 (0) 741 / 9 42 05 - 50  
Email: [info@dieterle-tools.com](mailto:info@dieterle-tools.com)

[www.dieterle-tools.com](http://www.dieterle-tools.com)

