

SYSTEM MFE-IK

Internal machining with coolant supply

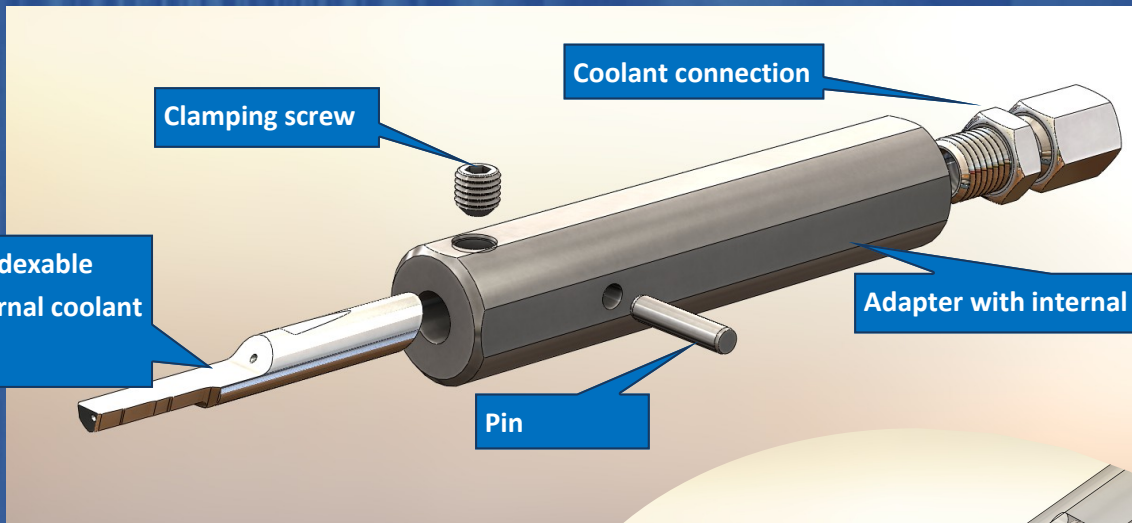

Solid carbide indexable insert with internal coolant supply

Clamping screw

Coolant connection

Adapter with internal coolant supply

Pin

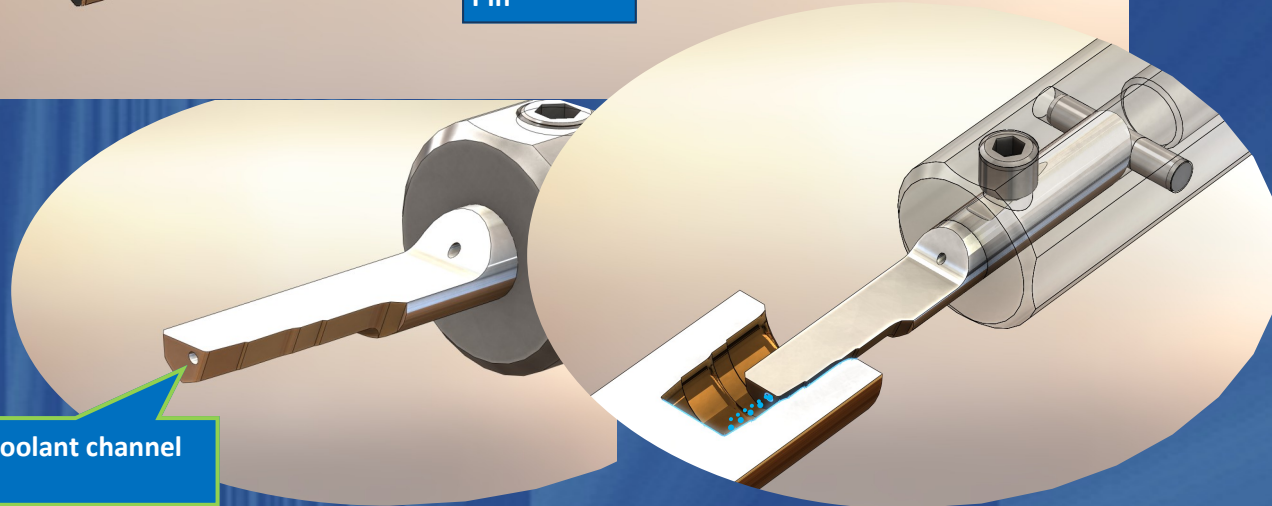

Internal coolant channel

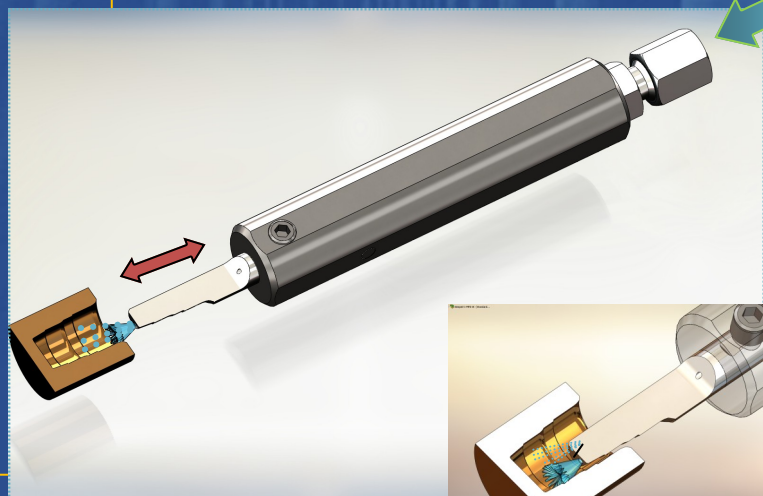

Best change accuracy and short changing time
Profile according to customer drawing (tolerance: $\pm 0,01\text{mm}$)
Application as:
- Internal form grooving tool
- Thread chaser

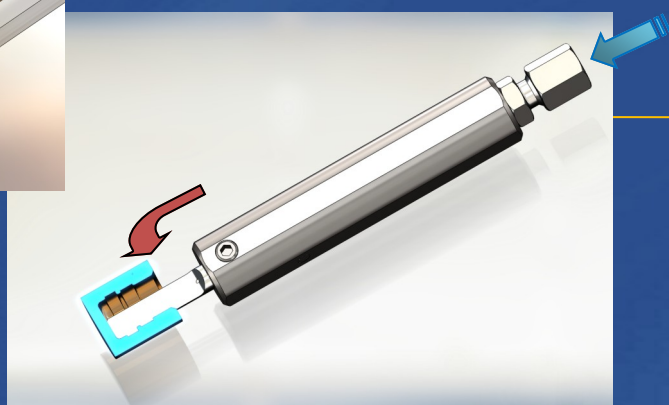
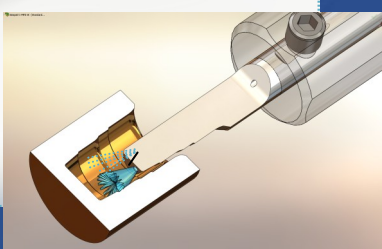

Internal machining with coolant supply

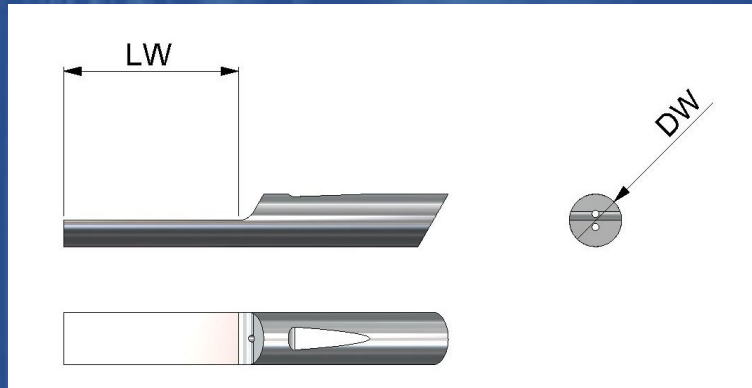

Solid carbide indexable insert

Ref.no.	Designation	DW	LW	carbide type
144396	MFE-IK-06-20-HM	6	20	K40UF
144395	MFE-IK-08-25-HM	8	25	K40UF
144392	MFE-IK-10-30-HM	10	30	K40UF

Accessory

Designation

Gewindesttift	M5x5-N-ISO 4029
Zylinderstift	Ø3x14-A-St. ISO 8734
IK-Anschluß	GE-04LLM-CF M8x1

Pin

Coolant connection

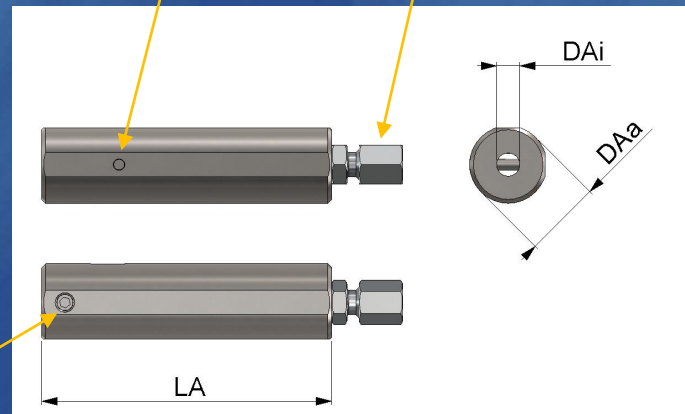

Thread pin

Adapter with internal coolant

Ref.no.	Designation	DAi	DAa	LA
144390	MFE-IK-06-20-A-16	6	16	75
144388	MFE-IK-06-20-A-20	6	20	75
144386	MFE-IK-08-25-A-16	8	16	75
144385	MFE-IK-08-25-A-20	8	20	75
144383	MFE-IK-10-30-A-16	10	16	75
144381	MFE-IK-10-30-A-20	10	20	75

Otto Dieterle Spezialwerkzeuge GmbH

Predigerstr. 56, 78628 Rottweil, Germany Telefon: 0741/94205-0 Fax: 0741/94205-50 info@dieterle-tools.com

www.dieterle-tools.com