

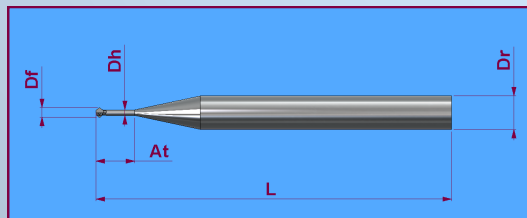

= SYSTEM-MFF = Mini-Form End Mills

Chamfering, Deburring, Cutting, Reverse Lowering

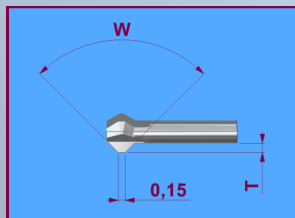
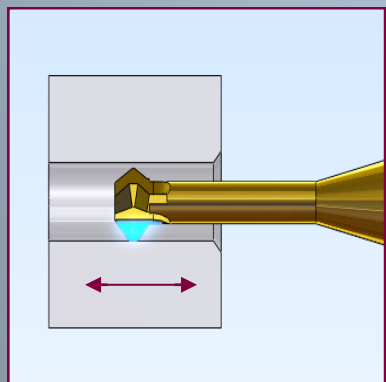
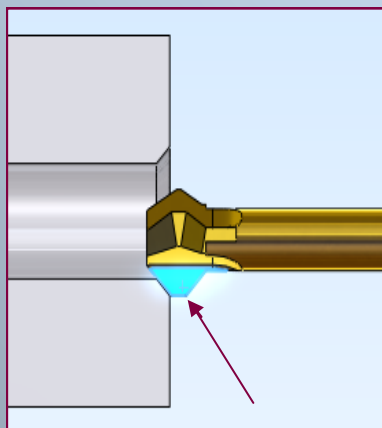

End mill \varnothing (Df) from 0,6 mm up to 6,2 mm
Angle (W): 60°/90°/120°

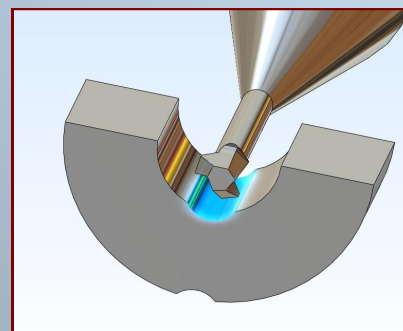
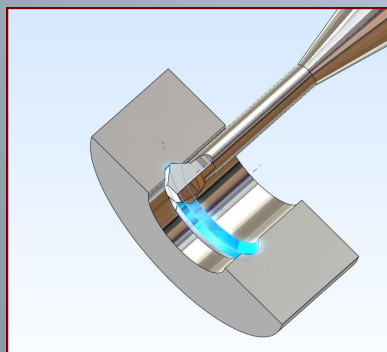
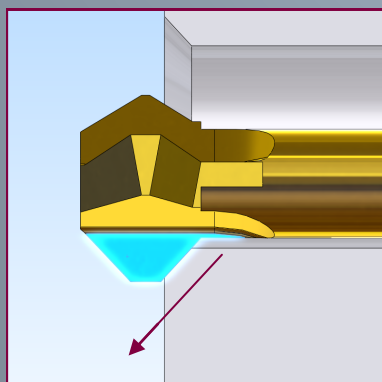

Otto Dieterle Spezialwerkzeuge GmbH
Predigerstr. 56, 78628 Rottweil, Germany
Telefon: 0741/94205-0 Fax: 0741/94205-50
info@dieterle-tools.com
www.dieterle-tools.com

ANGLE 90°

= System-MFF =
Mini-Form End Mills

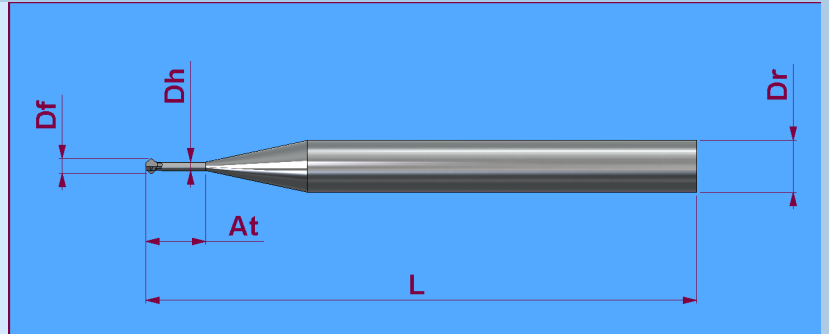
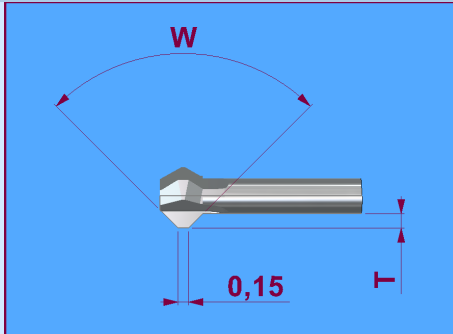
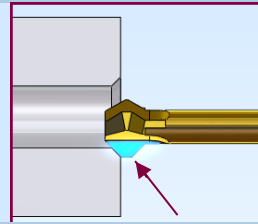
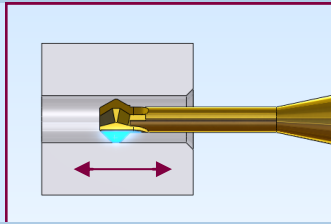
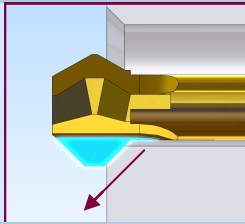

Df ($\pm 0,01$) = end mill diameter
 Dh ($-0,02$) = neck diameter
 $T = (Df - Dh) / 2$ = penetration depth
 W = Winkel = angle

At ($+0,2$) = neck length
 S = number of flutes
 Dr (h5) = blank diameter
 L ($\pm 0,1$) = length

1. - Series-45 (angle=90°)

Special executions possible

Designation	Df	Dh	T	W	At	S	Dr	L
MFF-0603-45-L2-32-2S	0,6	0,3	0,15	90°	2	2	3	32
MFF-0905-45-L3,5-32-3S	0,9	0,5	0,20	90°	3,5	3	3	32
MFF-1206-45-L4-32-3S	1,2	0,6	0,30	90°	4	3	3	32
MFF-1808-45-L5-32-3S	1,8	0,8	0,50	90°	5	3	3	32
MFF-2710-45-L7-32-4S	2,7	1,0	0,85	90°	7	4	3	32
MFF-3018-45-L7-40-4S	3,0	1,8	0,60	90	7	4	4	40
MFF-3520-45-L7-40-4S	3,5	2,0	0,75	90°	7	4	4	40
MFF-4025-45-L10-40-4S	4,0	2,5	0,75	90°	10	4	5	40
MFF-4030-45-L10-40-4S	4,0	3,0	0,50	90°	10	4	5	40
MFF-4525-45-L12-40-4S	4,5	2,5	1,00	90°	12	4	5	40
MFF-4830-45-L12-40-4S	4,8	3,0	0,90	90°	12	4	5	40
MFF-5030-45-L28-80-4S	5,0	3,0	1,00	90°	28	4	8	80
MFF-5530-45-L28-80-4S	5,5	3,0	1,25	90°	28	4	8	80
MFF-6030-45-L28-80-4S	6,0	3,0	1,50	90°	28	4	8	80
MFF-6240-45-L28-80-4S	6,2	4,0	1,10	90°	28	4	8	80

ANGLE 60°

= System-MFF =
Mini-Form End Mills

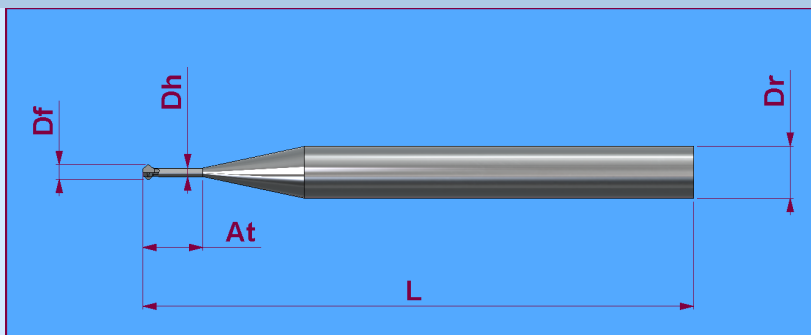
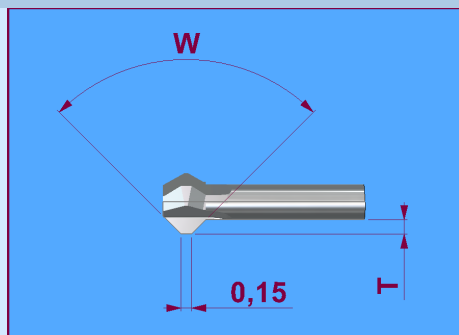
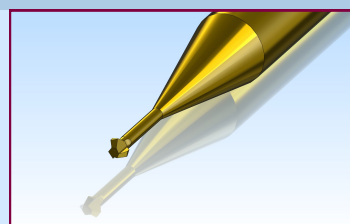
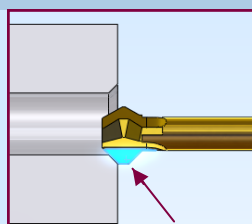
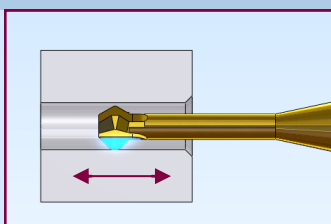
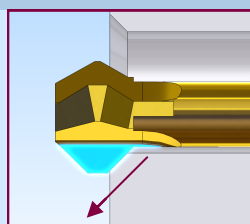

Df ($\pm 0,01$) = end mill diameter
 Dh ($-0,02$) = neck diameter
 $T = (Df - Dh) / 2$ = penetration depth
 W = angle

At ($+0,2$) = neck length
 S = number of flutes
 Dr (h5) = blank diameter
 L ($\pm 0,1$) = length

1. - Series-30 (Angle=60°)

Special executions possible

Designation	Df	Dh	T	W	At	S	Dr	L
MFF-0603-30-L2-32-2S	0,6	0,3	0,15	60°	2	2	3	32
MFF-0905-30-L3,5-32-3S	0,9	0,5	0,20	60°	3,5	3	3	32
MFF-1206-30-L4-32-3S	1,2	0,6	0,30	60°	4	3	3	32
MFF-1808-30-L5-32-3S	1,8	0,8	0,50	60°	5	3	3	32
MFF-2710-30-L7-32-4S	2,7	1,0	0,85	60°	7	4	3	32
MFF-3018-30-L7-40-4S	3,0	1,8	0,60	60	7	4	4	40
MFE-3520-30-L7-40-4S	3,5	2,0	0,75	60°	7	4	4	40
MFF-4025-30-L10-40-4S	4,0	2,5	0,75	60°	10	4	5	40
MFF-4030-30-L10-40-4S	4,0	3,0	0,50	60°	10	4	5	40
MFF-4525-30-L12-40-4S	4,5	2,5	1,00	60°	12	4	5	40
MFF-4830-30-L12-40-4S	4,8	3,0	0,90	60°	12	4	5	40
MFF-5030-30-L28-80-4S	5,0	3,0	1,00	60°	28	4	8	80
MFF-5530-30-L28-80-4S	5,5	3,0	1,25	60°	28	4	8	80
MFF-6030-30-L28-80-4S	6,0	3,0	1,50	60°	28	4	8	80
MFF-6240-30-L28-80-4S	6,2	4,0	1,10	60°	28	4	8	80

ANGLE 120°

= System-MFF =
Mini-Form End Mills

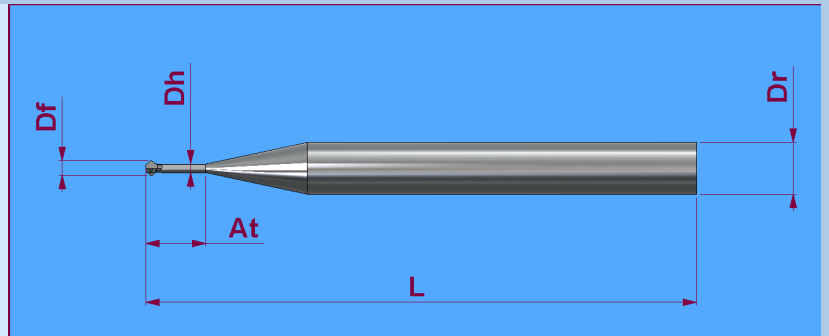
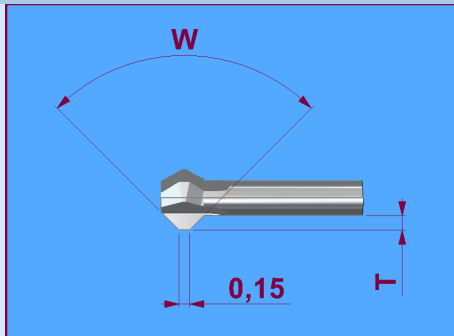
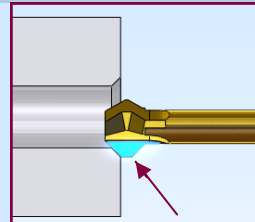
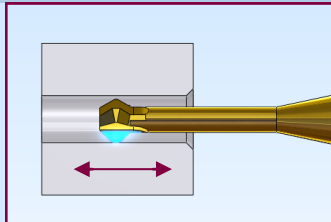
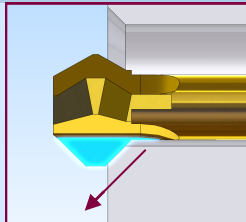

Df ($\pm 0,01$) = end mill diameter
 Dh ($-0,02$) = neck diameter
 $T = (Df - Dh) / 2$ = penetration depth
 W = Winkel = angle

At ($+0,2$) = neck length
 S = number of flutes
 Dr ($h5$) = blank diameter
 L ($\pm 0,1$) = length

1. - Series-60 (angle=120°)

Special executions possible

Designation	Df	Dh	T	W	At	S	Dr	L
MFF-0603-60-L2-32-2S	0,6	0,3	0,15	120°	2	2	3	32
MFF-0905-60-L3,5-32-3S	0,9	0,5	0,20	120°	3,5	3	3	32
MFF-1206-60-L4-32-3S	1,2	0,6	0,30	120°	4	3	3	32
MFF-1808-60-L5-32-3S	1,8	0,8	0,50	120°	5	3	3	32
MFF-2710-60-L7-32-4S	2,7	1,0	0,85	120°	7	4	3	32
MFF-3018-60-L7-40-4S	3,0	1,8	0,60	120°	7	4	4	40
MFF-3520-60-L7-40-4S	3,5	2,0	0,75	120°	7	4	4	40
MFF-4025-60-L10-40-4S	4,0	2,5	0,75	120°	10	4	5	40
MFF-4030-60-L10-40-4S	4,0	3,0	0,50	120°	10	4	5	40
MFF-4525-60-L12-40-4S	4,5	2,5	1,00	120°	12	4	5	40
MFF-4830-60-L12-40-4S	4,8	3,0	0,90	120°	12	4	5	40
MFF-5030-60-L28-80-4S	5,0	3,0	1,00	120°	28	4	8	80
MFF-5530-60-L28-80-4S	5,5	3,0	1,25	120°	28	4	8	80
MFF-6030-60-L28-80-4S	6,0	3,0	1,50	120°	28	4	8	80
MFF-6240-60-L28-80-4S	6,2	4,0	1,10	120°	28	4	8	80